

ACCESS

# ALTURA GOLD PRODUCT CATALOGUE

## Discover Luxury

**Altura Gold, the easy all-in-one home lift solution, based on Spindle technology, to effortlessly enhance your home comfort**

Altura Gold - the smallest home lift

The smallest and most compact home lift in our product range. The lift has been designed to meet all requirements for comfort, space and design in narrow environments. The lift is available in different sizes, with an option to personalize it with details such as glass walls, a range of varied colours and different materials.



## Altura Gold - the smallest home lift

The smallest and most compact home lift in our product range. The lift has been designed to meet all requirements for comfort, space and design in narrow environments. The lift is available in different sizes, with an option to personalize it with details such as glass walls, a range of varied colours and different materials.

<b>Technical compliance</b>	European Machine directive 2006/42/EC European standard EN 81-41
<b>Drive system</b>	Screw/nut system
<b>Max speed</b>	Max. 0,15 m/s
<b>Rated Load</b>	250 kg
<b>Travel height</b>	900 - 12000 mm
<b>Distance between intermediate floors (Masonry / Metal Shaft)</b>	min. 250 mm opposite accesses min. 2300 mm adjacent accesses
<b>Number of stops</b>	Max. 6 stops per lift
<b>Number of doors</b>	Max. 6 doors per lift
<b>Number of doors per floor</b>	Max. 1 doors per floor
<b>Pit</b>	50 mm (no pit is required when there is a threshold/ramp)
<b>Shaft Top height (Masonry / Metal Shaft)</b>	Standard 2430 mm (elongation is possible)
<b>Platform control</b>	“Hold to run”
<b>Landing control (on door)</b>	One-touch call
<b>Environment</b>	Indoor
<b>Emergency lowering</b>	Battery operated emergency lowering
<b>Control voltage</b>	24V
<b>Motor</b>	1,5kW
<b>Power requirements</b>	1-phase 230Vac 50/60Hz - Max Power 3 kW
<b>Circuit Breaker / RCD</b>	16A Tripping curves C / 30mA class A or B

Platform size B-side x A/C-side (mm)	Max load (kg)
800 x 580	250
800 x 845	250
800 x 1100	250

### Platform

- Altura Gold is available in 3 different platform sizes.
- The Platform has a Full Height Panel
- The rated load is 250 kg and the required power supply is 230 V 1-phase.

# Platform



## Platform Altura Gold

### 1 Full height panel

The platform is delivered with a full height wall including the control operation panel and the handrail. It comes with LED lightening as standard.

The wall is Skinplate A4, but as an option can be:

- ◆ executed in other skinplate finishes
- ◆ painted in any RAL colour

Available for Altura Gold only.

Width: 800 mm

Height: 2200 mm.

### 2 Control Panel & Handrail

Control Panel is black mirror and comes with white LED backlight. Handrail is Black standard and can be order as option in Stainless Steel.

### 3 Telephone

### 4 Platform

Provided with vinyl floor and safety edges. A,B,C and G-side of platform.

## Dimensions

Altura Gold is available in several different plan sizes. This overview illustrates the free space on the platform floor, according to relevant code. For more detailed drawings see the annex. Doors on side A/C are possible for 800×1100 plan. For frontal access (B/B side) or adjacent accesses (A/B or B/C sides) minimum distance between floors is 2300 mm. For opposite accesses (A/C sides) minimum distance between intermediate floors is 250 mm.

800×580

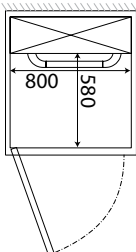

800×845

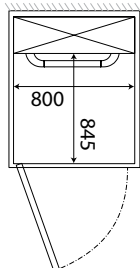

800×1100

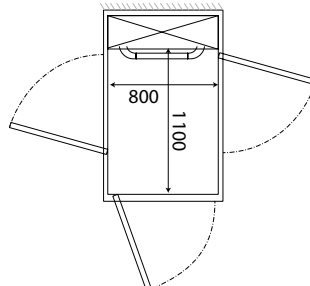

# Platform - Main features

## 1 Control Operation Panel

The control panel is always placed on the machine side (G-side) of the platform. It contains the destination buttons, the emergency stop and the alarm button. As an option it can contain an autodialer, a key switch and a colour display with landing indicator and voice announcer. It has a backlight all around the profile which emphasizes the design of the panel.

The location of the platform buttons and the handrail conform to EN 81-41

## 2 Destination buttons

Destination buttons conform to EN 81-41. The location of the buttons are within the limits in the standard, i.e. height between platform floor and the centre line of the buttons is between 900-1100 mm.

Standard buttons are engraved with braille.  
Diameter of buttons in vertical panel: 37 mm  
Following buttons are available:

-2, -1, 0, 1, 2, 3, 4, 5, 6, B, BG, BV, G, K, KV, P, U, E.

## 3 Alarm button

A standard alarm button is always delivered with the lift. The alarm button is connected to an external alarm sounder and to an optional autodialer.

When it is pressed, a siren sounds.

Keep it pressed for 3 seconds to activate the emergency call with the optional autodialer.

## 4 Emergency stop button

Red Button for emergency situations is always included as standard.

## 5 Handrail

A handrail is mandatory according to EN81-41 and delivered as standard in black finish.  
The height between platform floor and top edge of the handrail is between 875 - 925 mm.  
Minimum cross-sectional dimension is 30 mm.

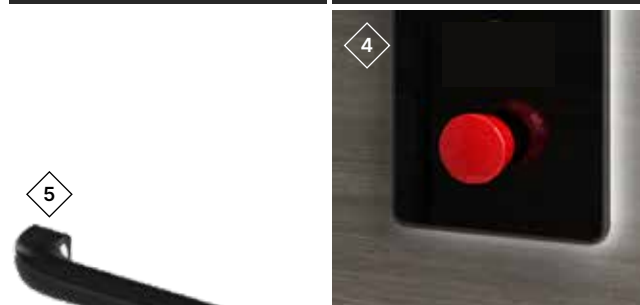
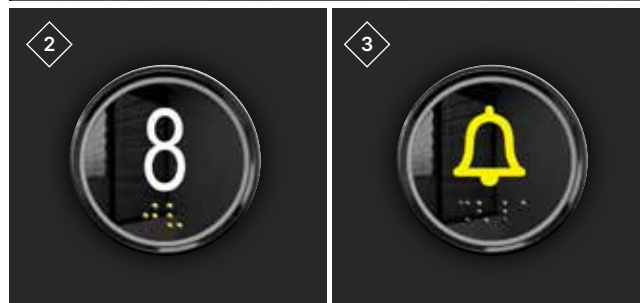

### 6 External alarm sounder

The alarm sounder is delivered within a box to be mounted outside the lift. It is connected to the alarm button and when the alarm button is pressed the siren will give a loud signal outside the lift to attract attention in case of emergency.

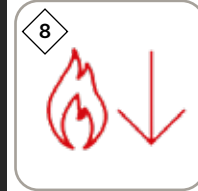

### 7 Display and Landing indicator

The colour digital display is positioned on the control panel. It shows which floor the lift is on at the moment.

The landing indicator can also show the following information from the system:

- ◆ Direction of the lift when travelling
- ◆ Icons for the different status of the lift
- ◆ Error code for diagnostic
- ◆ If connected to the buildings fire alarm a symbol will be shown when alarm is activated.

The display can be ordered as an option and different audio options can be selected:

- ◆ No acoustic signal
- ◆ Acoustic signal in the cabin and at landings
- ◆ Voice announcer at cabin and acoustic signal at landings

Available languages for the voice announcer are: English, Italian, French, German, Spanish, Dutch, Portuguese, Czech and Russian.



### 8 Building Integration

The lift can be connected to the building's fire alarm. In case of fire, a symbol on the display will be shown when the alarm is activated and the lift will move to a predetermined floor and park there.

A specific customers's declaration is needed to integrate this option in the system.

### 9 Key switch on platform

Key switch placed on the control panel. The key switch locks the platform functions and prohibits unauthorized use.

Two options to choose from:

- ◆ mechanical key
- ◆ i-button

Can be ordered as option. One key switch per platform can be provided. The key switch can only be connected to all destination buttons.



Mechanical key

We supply two keys per each switch. Extra keys can be provided on request.



i-button

We supply one (black) i-button per each selective switch or LOP switch. Two (black) i-buttons in case of overall cabin switch. Extra buttons can be provided on request. Red i-button is for installation only.

# Standard Cabin - Finishes

## Flooring

Choose between the following options for safety vinyl flooring with guaranteed life time non-slip.



White Vinyl



Sand Vinyl

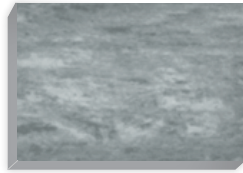

Grey Vinyl

Choose to have your lift delivered without flooring, if you want to apply your own. Max 3 mm flooring for flush top alignment.

## Platform Wall

RAL Colour suggested for painted parts to match with the pre-coated steel.

### PRE-COATED STEEL - PLAIN

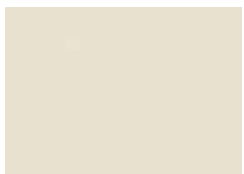

A4 (standard) - similar to RAL9010

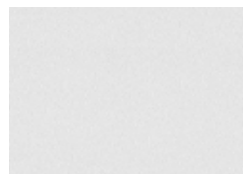

A1 - similar to RAL9003



A13 - similar to RAL1013



N1 - similar to RAL7035



PPS - Metal Like - similar to RAL7037

Pre-coated steel is a quality material where one side of a galvanized steel sheet is industrially coated with a layer of PVC film which guarantees high aesthetic value and durability.

### PRE-COATED STEEL - PPS



PPS1 - similar to RAL 7035

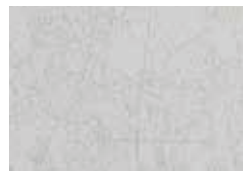

PPS10 - similar to RAL 9003

### RAL PAINT OF CHOICE



Please refer to FAQ Section

### STAINLESS STEEL



Stainless Steel Satin

Pictures are purely indicative and cannot be considered controlled samples.

Sample kits are available on request.

Contents subject to change without notice

# Doors

## Doors Altura Gold

### General information

The doors installed at each landing are made of steel. Doors can be blind or panoramic. All doors are painted in RAL 9010 (White) but can be painted in any RAL colour as an option. The door frame is painted in the same colour as the door. Panoramic doors have a safety glass 10/11 mm thick. Standard is with transparent glass. Optional: Smokey Grey, Smokey Satin, Opalin or Half Reflecting glass. The profiles around the glass are made of aluminium. The profiles can be painted in any RAL colour as an option. Doors on side B are 800 mm and can be left or right hinged. Doors on side B are without vertical frame to maximize the net opening. Doors on side A/C are possible for 800×1100 plan size and are always delivered with a frame. Doors on side A/C can be 800 mm or 900 mm

### Panoramic door

Door with one glass window.

**Opening widths:** 800 mm (side B) | 800 / 900 mm (side A/C)  
**Opening heights:** standard: 2000 mm. Option: 1800, 1900 mm  
**Glass window:** 715×1460 mm for standard 800 mm door

**Standard:**

- ◆ Door and door frame in RAL 9010 (White)
- ◆ Glass window: Transparent Glass

**Options:**

- ◆ Door and door frame in other RAL colour
- ◆ Glass window: Smokey Grey, Smokey Satin, Opaline or Half Reflecting

Door opening width (mm)	Door opening height (mm)	Available for B-side (mm)	Available for A/C side (mm)
800	1800 / 1900 / 2000	800	1100
900	1800 / 1900 / 2000	800	1100

### Door frame and actual height

The height of the door frame depends on the door net height and is 140/160 mm higher than the door opening height. The actual height of the door is 40 mm higher than the net height.

Door net height (mm)	Door actual height (mm)	Frame height side B (mm)	Frame Height side A/C (mm)
1800	1840	1960	1940
1900	1940	2060	2040
2000	2040	2160	2140



Panoramic door side C



Panoramic door side B

# Door options

## Door control

The door control is either placed on the door frame of each landing door and/or placed away from the lift as an external control.

## Door control on door frame

Door control placed on the door frame on the A and C side of the lift. An external call box is supplied for doors on side B

### Door faceplate

The door faceplate is stainless steel satin.

The door faceplate can include:

- ◆ Call button
- ◆ Key switch
- ◆ i-button
- ◆ LCD display
- ◆ Key switch prepared for EUR (Model 393/211)

### Key switch / School locking

Instead of having a normal call button on the door faceplate, a key switch is possible. The user needs to have the key to be able to call and access the lift. It includes school locking function which automatically locks the door after an adjustable time.

We can provide one key switch per door only.

### Call button

The call button comes with a background lit frame which indicates the status of the lift.

- ◆ Green light indicates that the lift is at your floor. Lit only on the floor where the platform is at the moment.
- ◆ Red light indicates that the lift is occupied. It is busy and you can't call it.
- ◆ The flashing light indicates that the security circuit is broken, e.g. that the emergency button is pressed, the door is open on another floor for more than one minute, the door is blocked or the safety frame is pressed down. The flashing light can also be activated by an alarm, more information is then available in the service memory.

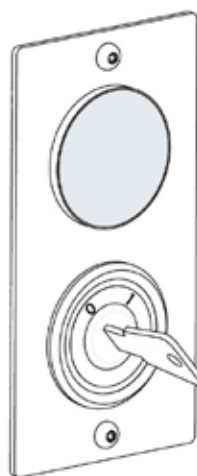
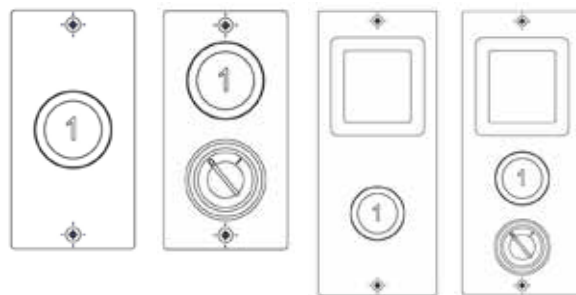

Operation & Call Key

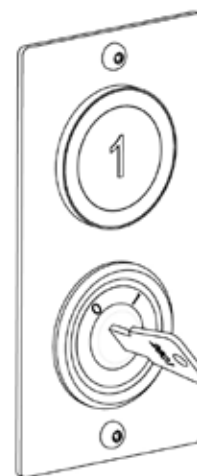

Operation Key and Push Button



## Cable or Radio control station – placed away from lift

Door control placed away from the lift in an external call box connected to the lift via a cable or wireless.

When having a door on the B-side, there is no frame and thus no place for a door faceplate. The standard solution is to have the call button in an external call box connected to the lift via a cable. Optionally a wireless radio control station can be ordered.

**Size:** 130×70×55 mm without display / 220×95×55 mm with display

**Finish:** The faceplate is stainless steel satin.

The case of the call boxes for surface mounting is RAL9010

The call box can be Surface Mounted or Flush Mounted. The Radio control station is available in three different configurations:

- ◆ Push Button only
- ◆ On/off Key switch + push button
- ◆ Prepared for Eurokey

The radio control station cannot be configured with a display.

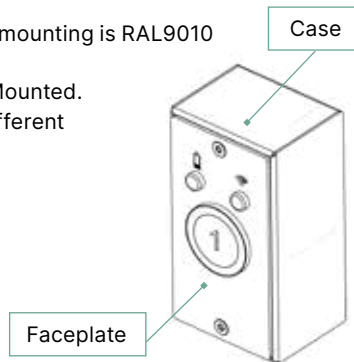

## Door handle

One stainless steel handle is provided as standard with each landing door.

## Call box for flush wall mounting

Recommended dimensions for mounting

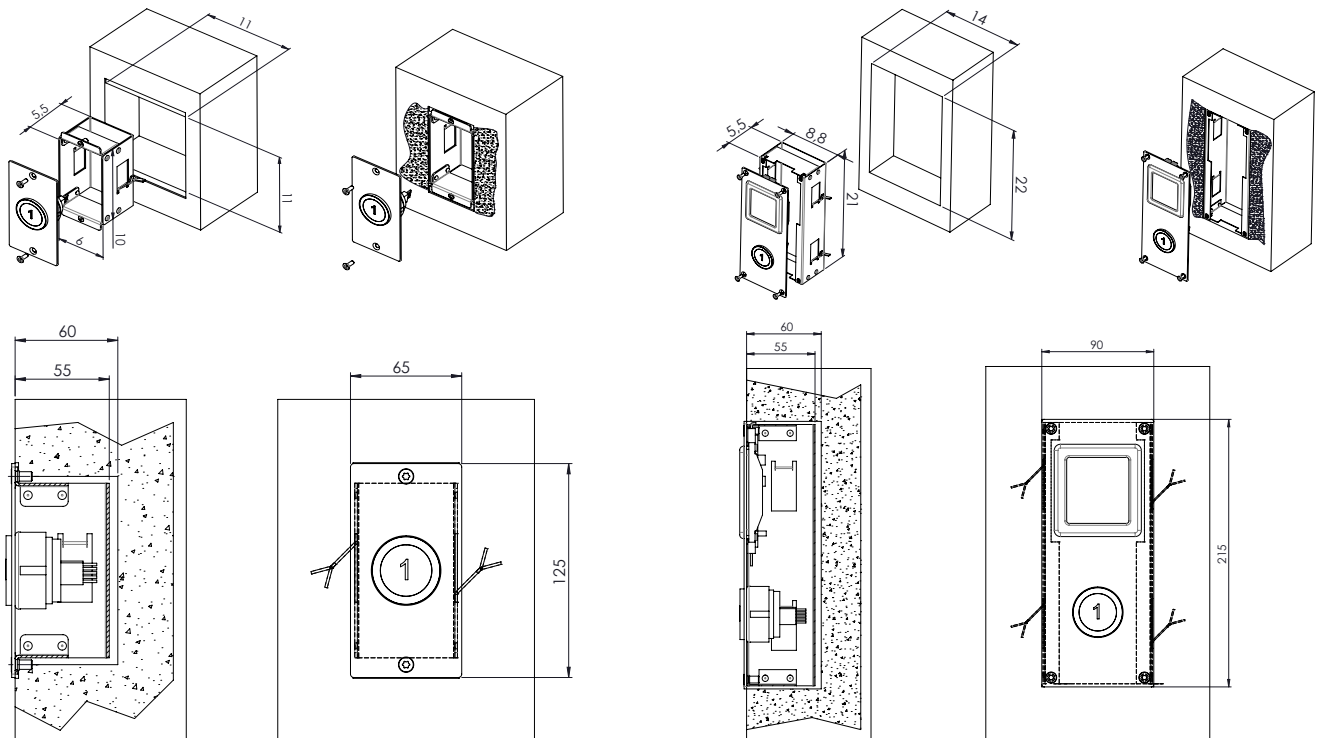

## Landing indicator on door

Digital display positioned at the door frame. It shows which floor the lift is on at the moment.

The landing indicator can also show the following system information:

- ◆ Direction of the lift when travelling
- ◆ A bell when the alarm button has been pressed.
- ◆ A weight symbol will appear if the lift is overloaded.
- ◆ Error code for diagnostics
- ◆ Out of service state

Can be ordered as option. Not available for Radio control Station.

Standard doors are semi-automatic which means that they are opened manually and they close automatically. The closing speed and time cannot be adjusted.



## External door opener - optional

An automatic door opener can be ordered as option. It opens and closes the door automatically. Door opening / closing time and speed are adjustable.

The cover is always painted white.

When having two doors with door openers on the same landing, both doors will be opened at the same time.



## Internal door closer

Standard on Altura Gold.

It closes the door automatically. It is built into the door frame and is invisible from the outside. Optionally, it includes the function to keep the door open until the user manually closes the door. Closing speed can be adjusted.



## Ramp

If the lift is installed without a pit a ramp is mandatory according to EN81.41. The ramp is made of aluminium and prevent slipping. The vertical rise of the ramp is less than 1:4. Ramp dimensions: Height 50 mm, width 460 mm, as long as the shaft side where it is installed.



# Shaft

The lift is always delivered with a metallic shaft. The top height of the shaft (distance from top floor to top of shaft) is always 2430 mm.

Elongation of the shaft is possible. Please allow a free height of min. 20 mm from the ceiling of the building to allow for installation.

The lift always has to be installed against a load bearing wall.

The machine side is not cladded. For all sides except for the machine side you can choose to have shaft panels in steel or glass.

## Inner ceiling

The lift always comes with an inner ceiling, painted in the same colour as the shaft walls. Standard is RAL 9010 (white). If the shaft is painted in another RAL colour the inner ceiling is painted in the same colour.

## Shaft panels

Standard is 30 mm thick shaft panels with polyurethane and steel plate. The panels have a classified fire resistance of Bs2d0. The panels have a RAL 9010 finish (white) as standard. If painted in another colour, the shaft structure will be painted in the same colour. The standard height of th shaft panels is 1000 mm.

## Glass

As an option glass panels with laminated and toughened glass can be ordered. Different types of glass are available:

- 1 Transparent
- 2 Smokey Grey
- 3 Smokey Satin
- 4 Opaline
- 5 Half Reflecting.

The glass panels are 8/9 mm thick. The glass panels are fitted in aluminium profiles. As an option the profiles can be delivered RAL painted.

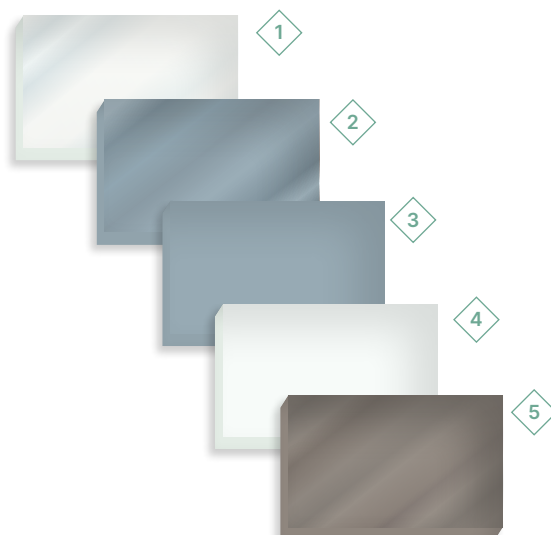

## Reinforcement Frame

With this optional feature, Altura Gold can be fixed to the pit and to the different landings with a vertical distance up to 3500 mm.

### “Position of fixing points”

Fixing side is always to the G-side (Machine Side). When ordering is important to provide the position (height) where fixing is feasible.

### “Free Headroom”

The shaft with reinforcement frame will be produced with a top headroom of 2430 mm. In case fixing at the top motor beam is not possible, additional vertical beams could be needed and shaft elongation not feasible.

### “Machine side Panels”

In case reinforcement frame is ordered, machine side can be cladded with the same panels used for the other sides. No glass panels are available for the machine side.

With the additional cladding of the machine side, the External Depth of the shaft increases by 32 mm. Thus the same applies to the dimensions for “through the floor” application.

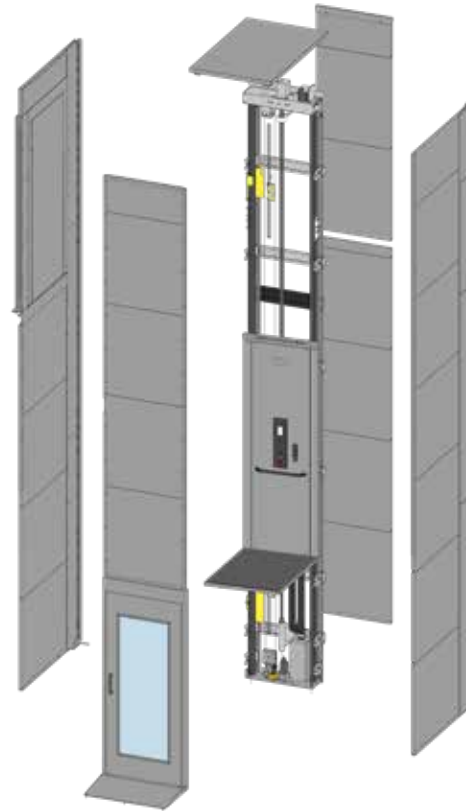

## Additional Fixing Elements

“Fastening Ring” - in combination with the “Reinforcement Frame” - allow fixing our home lift to the pit and to the landings only, independently from the presence of a supporting wall on the Guide side.

A typical application for Altura Gold with Fastening Rings is in in the eye of the staircase of a condominium building without supporting wall and fixation possible at landings only.

With the Fastening Ring, the External Depth of Altura Gold increases by 32 mm. Adding cladding panels on G-Side does not increase further the dimensions.

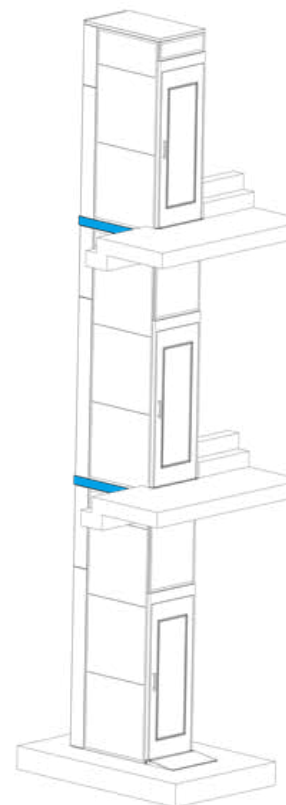

## Additional Fixing Elements - Specifications and Main characteristics

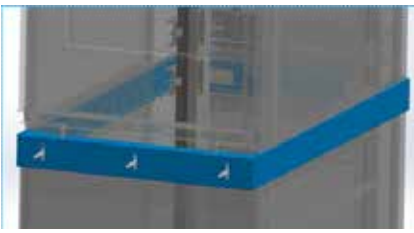
Altura Gold Fastening Ring	
	
<b>The fastening elements</b>	<p>allow the fixation of the lift on sides different from the G-side</p> <p>are structurally connected to the lift guides and to the building slab</p> <p>divide the shaft on 4 sides</p> <p>divide the shaft on 4 sides with a ring 115 mm high</p>
<b>Needs Reinforcement Frame</b>	Yes
<b>Needs Cladding Panels for G Side</b>	Yes, for safety reason when G-Side is accessible. Our optional cladding panels are designed for it.
<b>Sides for fixing and landing</b>	<p>Fixing and landing at side B. Doors at ground level feasible on any side, according to technical feasibility.</p> <p>Ring is typically fastened at landings and door sill to the Ring.</p>
<b>Finishes</b>	In the same color as shaft structure
<b>Available for plan size</b>	800×580 / 800×845 / 800×1100
<b>Minimum distance between floors</b>	2460 mm (standard door height 2160 mm + panel B-side height 300 mm)
<b>Maximum distance between fixing points</b>	3500 mm
<b>Lowest fixing point</b>	not below 2000 mm from pit.
<b>Upper fixing point</b>	not below 190 mm from top landing
<b>Dimensions through the floor</b>	The same as the Altura Gold with Reinforcement Frame and panels on G-Side
<b>Shaft Elongation</b>	Not possible
<b>Panels below bracket/ring</b>	A blind panel will be always used below each ring (to be cut on-site)
<b>Mixed fastening (some on G-Side, other with Brackets)</b>	Not possible

## Electrical cabinet - Altura Gold

The standard position of the electrical cabinet is in the shaft, at the lower floor.

An external service panel is available for mounting outside the lift as a standard. In this case a cable connects it with the service panel in the electrical cabinet.

## Service panel

It is used for maintenance purposes and for emergency running of the lift. It is always provided in a separate box to be wall mounted.

**Size of the separate box:** 220×95×57 mm key excluded

**Finish:** The faceplate is stainless steel satin.

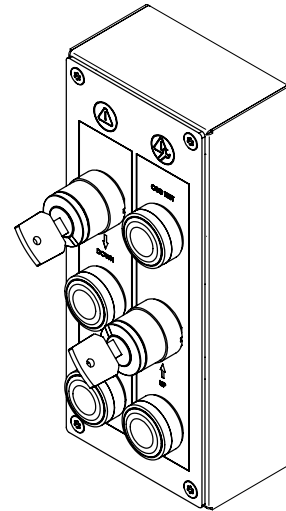

# Communication & drive



## Two way communication

Two way communication is mandatory according to EN81-41. Telephone landline required for standard configuration. As an option, GSM module can be added (SIM card not supplied). Choose from one of the following options.

### Autodialer

Equipment for emergency calls. Integrated in the control operation panel. Dials automatically when the alarm button is kept pressed for 3 seconds. When unanswered after a predefined time, the call is automatically forwarded to the next pre-set number. The autodialer can be equipped with a GSM module.

### Phone

The telephone works as a standard telephone but is intended for emergency calls only. The phone is mounted on the platform panel.

## Valuable standard features

### Battery operated emergency lowering

Battery operated emergency lowering is a standard feature in every lift. When there is a power failure, you can still travel downwards and get out by yourself. It is possible to run the lift to the nearest lower level pressing a destination button in the Control Operation Panel.

Can also be run externally from the Landing Operation Panel or from the Service Panel.

The battery guard ensures that the batteries are not damaged and that there is enough power to run the lift in the case of a power cut. It ensures that the lift is turned off when the batteries charge reaches a low predefined level.

### Automatic Lubrication

As a standard every lift is provided with an automatic lubrication device, which oils the driving screw regularly

### Soft start and stop.

It provides the lift with a smooth start and stop. It comes as a standard feature on all the lifts.

# FAQ

## 1. Can I have the lift painted in any colour?

Altura Gold standard colour is RAL9010 / Skinplate A4. Optionally, elements can be painted in any RAL colour. Colours are grouped in different classes with different pricing. Price level is lower for the most frequently used colours in our range. Also delivery times can differ per group.

RAL Colour Groups	Type of colours included
Group 1 High frequency	The 14 - most frequently ordered - not metallic RAL colours. This group include RAL9010 and the skinplate matching colours.
Group 2 Mid frequency	The 16 - often used - not metallic RAL colours
Group 3 Low frequency	44 not metallic RAL colours sometimes ordered
Any other RAL	Any other colour from the RAL chart K7 classic (year 2017). Pearl and Metal colours excluded.

RAL Colours Groups apply to all the painted components in our lift: Metal S / Platform Walls / Landing Doors.

RAL9010 is part of Group1. In other cases, it can be the standard finish included in the base price.

Metallic Colours (R06 / R07 / R09 / R10) are not available.

Painting for Shaft, Doors, Cabin is Coarse Texture, visual gloss.

Please refer to the annex for the complete list of colours and groups. Pictures are purely indicative and cannot be considered controlled samples. Sample kits are available on request.

All parts can show small colour differences, this is normal and unavoidable. While we take every precaution to minimize visible differences, this cannot be guaranteed.

## 2. To which standards do the lifts comply?

The Altura Gold complies with the Machine Directive 2006/42/EC, by following the harmonized standard EN 81-41.

The lifts are also compliant with the Electromagnetic Compatibility Directive EMC 2014/30/EU and Low voltage Directive 2014/35/EU. EI120 – fire & smoke proof door complies with the EN 81-58.

The lifts are type approved, CE marked. Certificates for all lifts are available on partner desktop.

### Skinplate Matching RAL Colours

RAL	Skinplate
RAL 9003	A1; PPS10
RAL 9010	A4
RAL 1013	A13; PPS11
RAL 1015	G1
RAL 5024	B13
RAL 7035	N1; PPS1
RAL 7037	Metal Like

"Any other RAL" colours are available with extra price and extra delivery time as a special request.

### Coarse Texture



Selecting high frequency RAL colors significantly reduces the powder-coating scrap rate with positive effect for the environment.





### 3. What are the reaction forces on the building and the force on the fixings which support the frame to the wall?

Details regarding the forces are available in the pre-installation manual.

#### Reaction forces from the lift to the building floor:

- ◆ Maximum force as a function of the lift’s travel.
- ◆ The force is distributed to the floor through the area “P” and the area “S”.
- ◆ The platform applies to the pit on the area "P" a force function of the travel and the model.
- ◆ The shaft applies to the shaft base area "S" a force function of the Shaft Height, model and panels. The force is applied on the perimeter of the shaft according to the standard plan.

#### Load from the lift to area “P”

Travel (m)	Altura Gold Load (kN)
2	6,3 / 6,7
3	6,5 / 7,0
4	6,7 / 7,2
5	6,9 / 7,4
6	7,1 / 7,6
7	7,3 / 7,8
8	7,5 / 8,0
9	7,7 / 8,2
10	7,9 / 8,4
11	8,1 / 8,6
12	8,3 / 8,8

#### Load from the lift to area “S”

Shaft Height (m)	Altura Gold - Load (kN)		
	Panel G-side	Panel	Glass
4,5	0,4	2,9	4,4
5,5	0,4	3,5	5,4
6,5	0,5	4,1	6,4
7,5	0,6	4,8	7,4
8,5	0,7	5,4	8,3
9,5	0,8	6,0	9,3
10,5	0,9	6,7	10,3
11,5	0,9	7,3	11,3
12,5	1,0	7,9	12,3
13,5	1,1	8,6	13,3
14,5	1,2	9,2	14,2

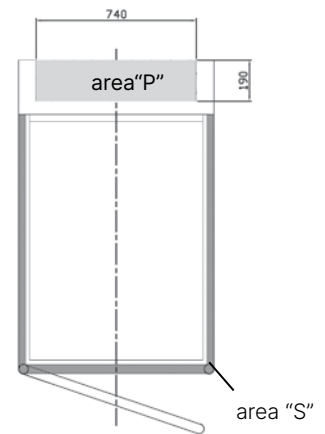

#### Reaction Force on the wall (rail side):

- ◆ The force is distributed to the wall through each crossbeam.
- ◆ Maximum force applied to each fixing point as a function of the lift’s rated load
- ◆ Vertical distance between each crossbeam for fixation  
Standard lift: 1100 mm  
Lift with reinforcement frame: 2000 - 3500 mm



(Different values refer to "standard lift" / "lift with reinforcement frame")

Model	Rated load [kg]	Maximum Reaction Force Fx [N]
Altura Gold	250	550 / 1130

# Features & Benefits

## You can always get out of the lift by yourself

If there is a power failure, you can always get out of the lift by yourself with battery operated emergency lowering. Use the platform buttons and the lift will take you to the nearest lower level where you can open the door and get out.

## The safest screw lift of its kind

For safety we prefer to count on more than one system. The overspeed governor and brake is separated from the main drive system. The electronics are certified by a third party with the highest safety Integration level for units of this kind.

## Minimum builders work and small footprint

The lift can be installed without a pit, with a ramp or with a 50 mm pit without ramp. All parts are included in the shaft - no extra machine room or head room is needed.

## Easy installation

Means that the lift is both easy and fast to install. A standard installation only takes two days.

## No need for a machine room

Traction machine is travelling with the cabin.  
Electrical board installed in the shaft.  
No additional space / cabinet needed.

## Low operation and maintenance cost

Lowest operation and maintenance cost on the market.  
Remote diagnostic system available as option.

## Compact and robust shaft

30 mm thick shaft panels. Robust and resistant to damage. Good noise and acoustic insulation.

# Drawings

## Typical layout & Plan sizes

This section illustrates shaft and platform dimensions according to the different car and access configurations. Also possible sides for door placement are visualized.

Drawings include dimensions for standard applications. Please consider extra mm for External Depth (ED) and Through-the-Floor Depth (FD) in case of:

- +32 mm to the standard in case of Machine Side Panels
- +32 mm to the standard in case of Fastening Ring. Adding cladding panels on Machine Side does increase further the dimensions

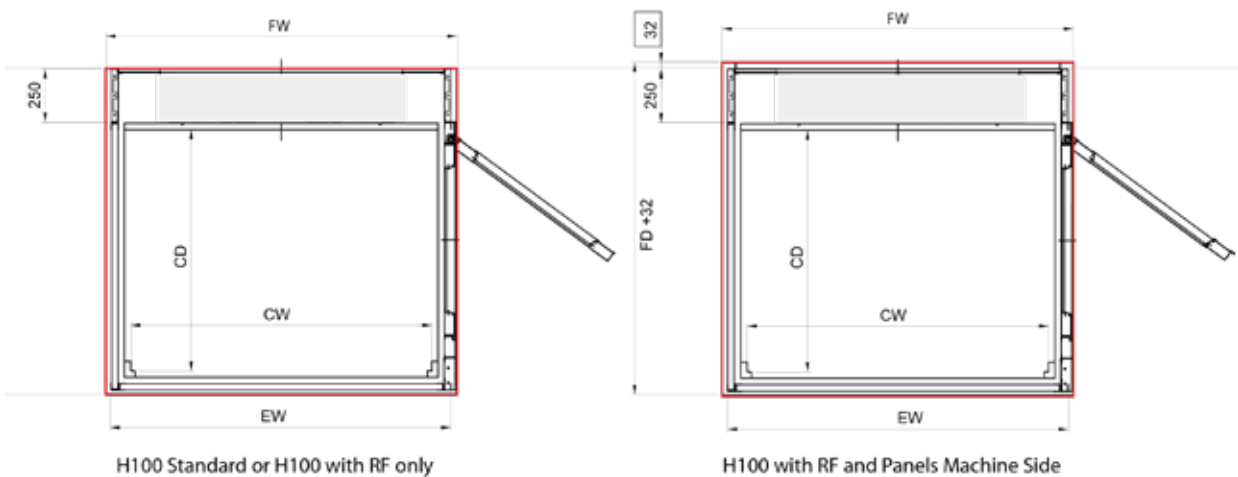

### 800×580

Platform: 800×580 mm  
 Doors: 800 mm  
 Access: Frontal only (Side B)  
 Load: 250 kg

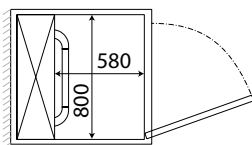

### 800×845

Platform: 800×845 mm  
 Doors: 800 mm  
 Access: Frontal only (Side B)  
 Load: 250 kg

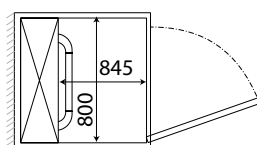

### 800×1100

Platform: 800×1100 mm  
 Doors Side B: 800 mm  
 Doors Side A/C: 800 or 900 mm  
**Access: Max one door at the same floor**  
 Load: 250 kg

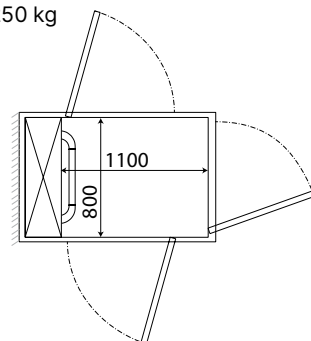

### Altura Gold - Full Panel 800×580 - Front

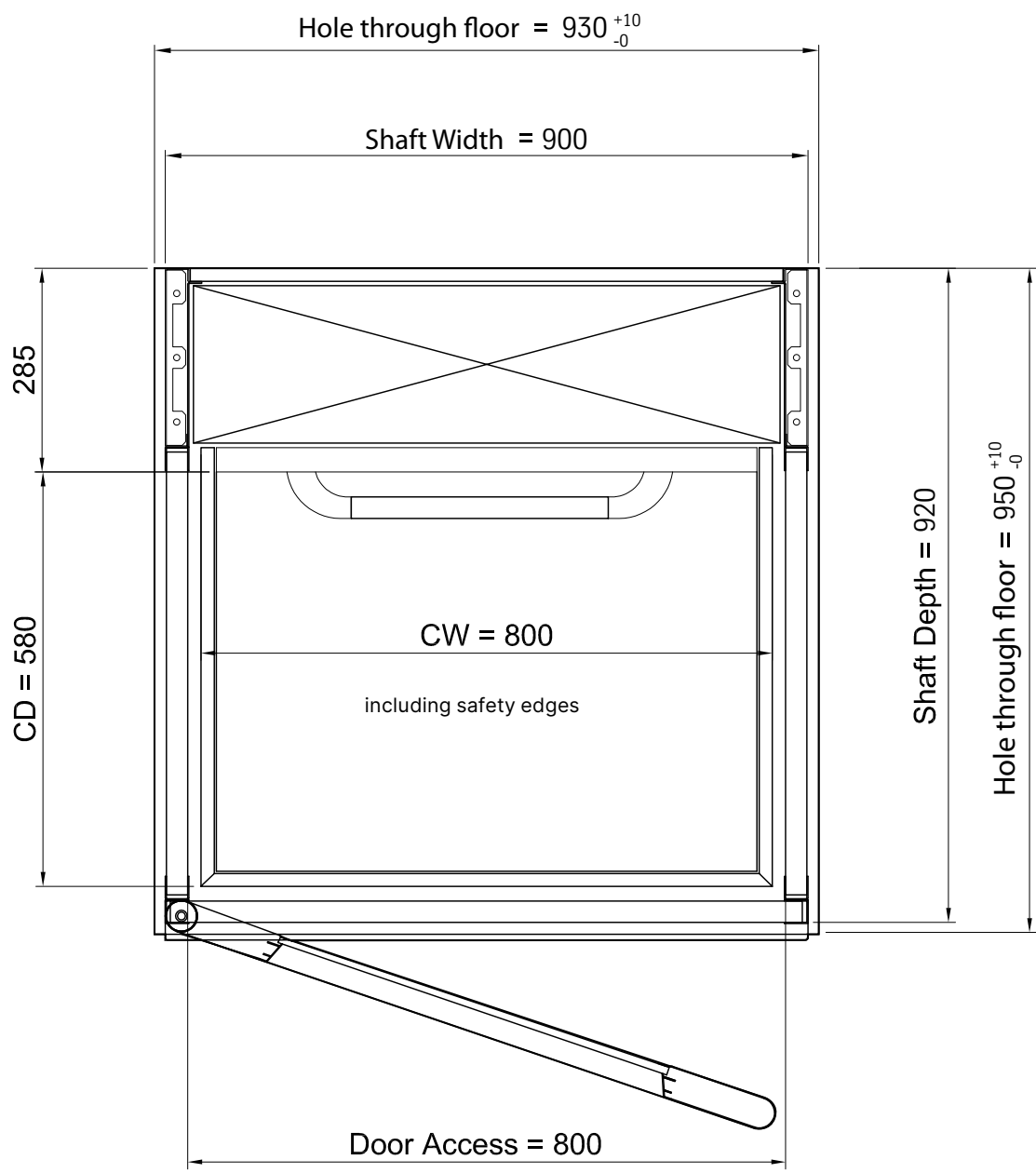

### Altura Gold - Full Panel 800×845 - Front

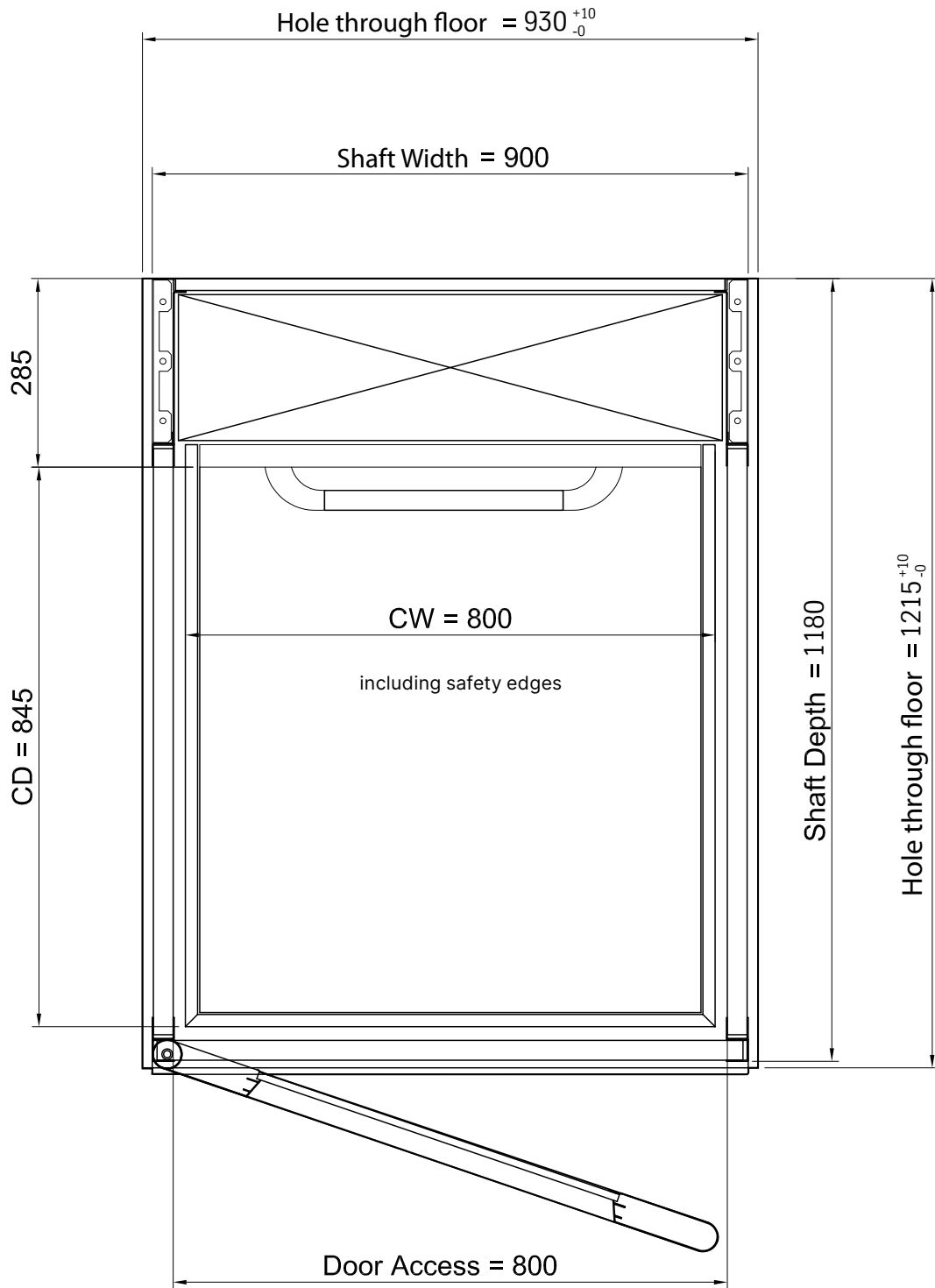

### Altura Gold - Full Panel 800×1100 - Front

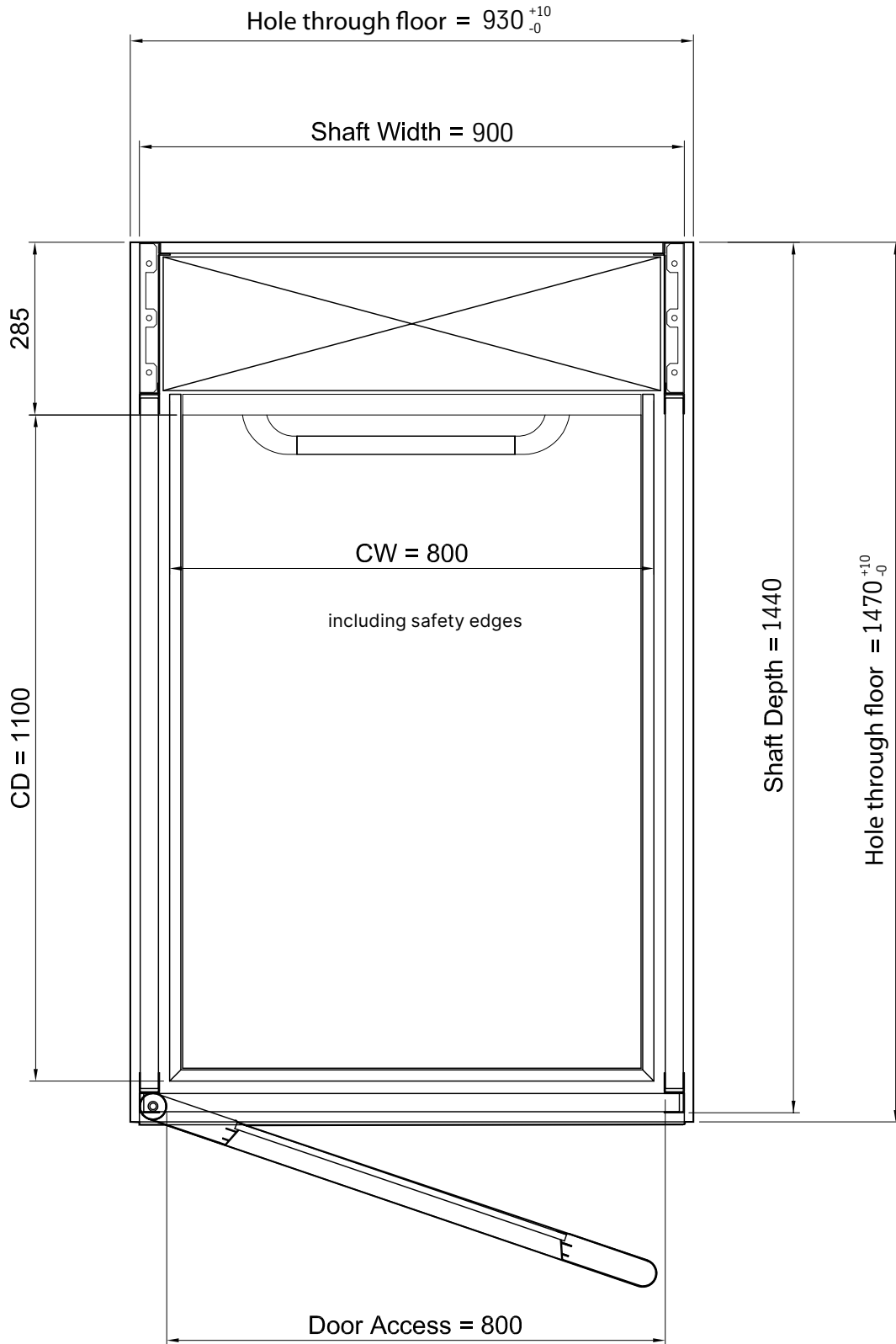

# Altura Gold - Full Panel 800×1100 - Opposite

Max one door at the same floor

This plan can be ordered with Doors 800 mm or 900 mm. It is not possible to have doors of different size on the same unit.

Opposite accesses are possible with doors at different floors with minimum distance of 250mm between floors

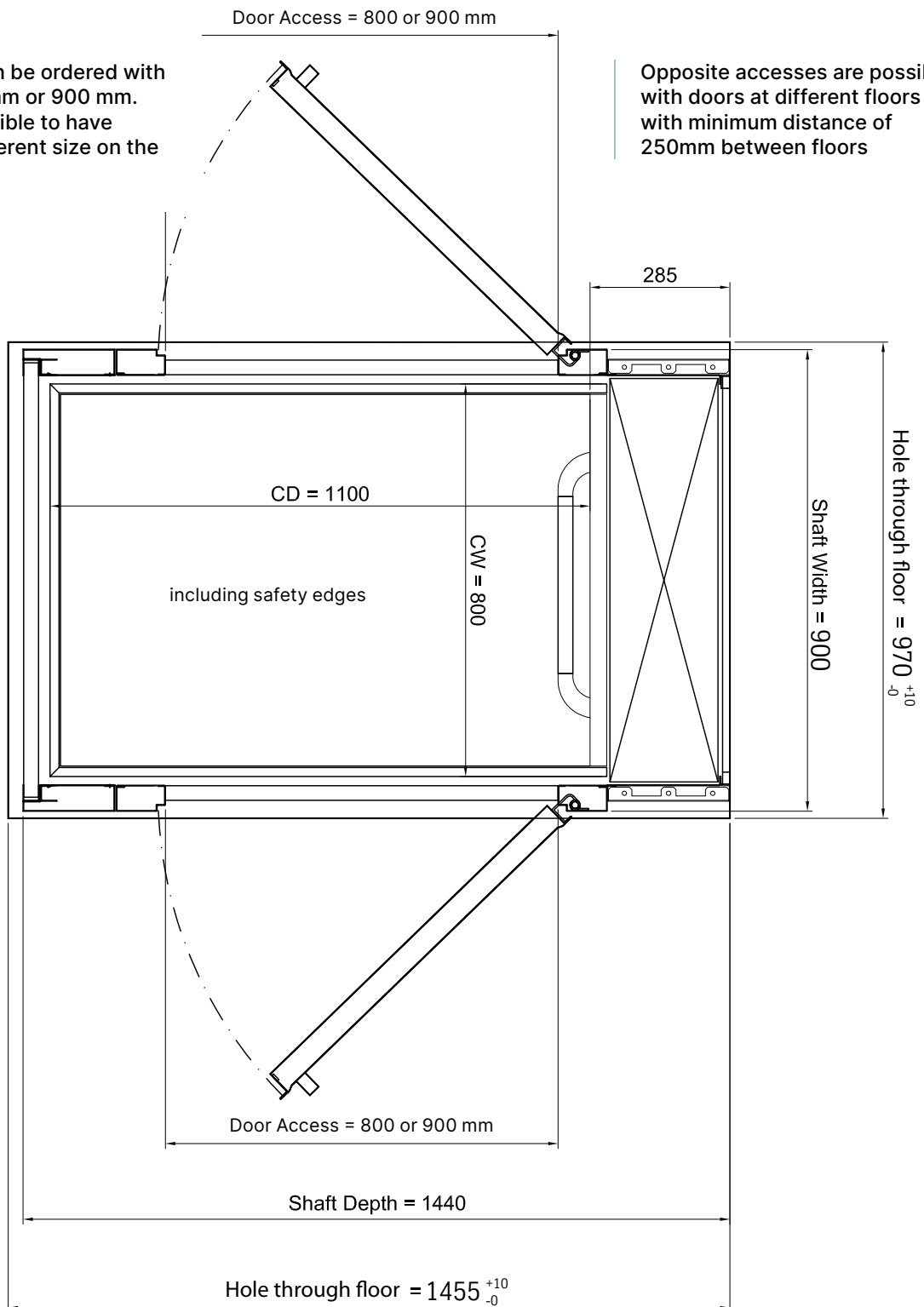

### Altura Gold - Full Panel - 800x1100 - Lateral

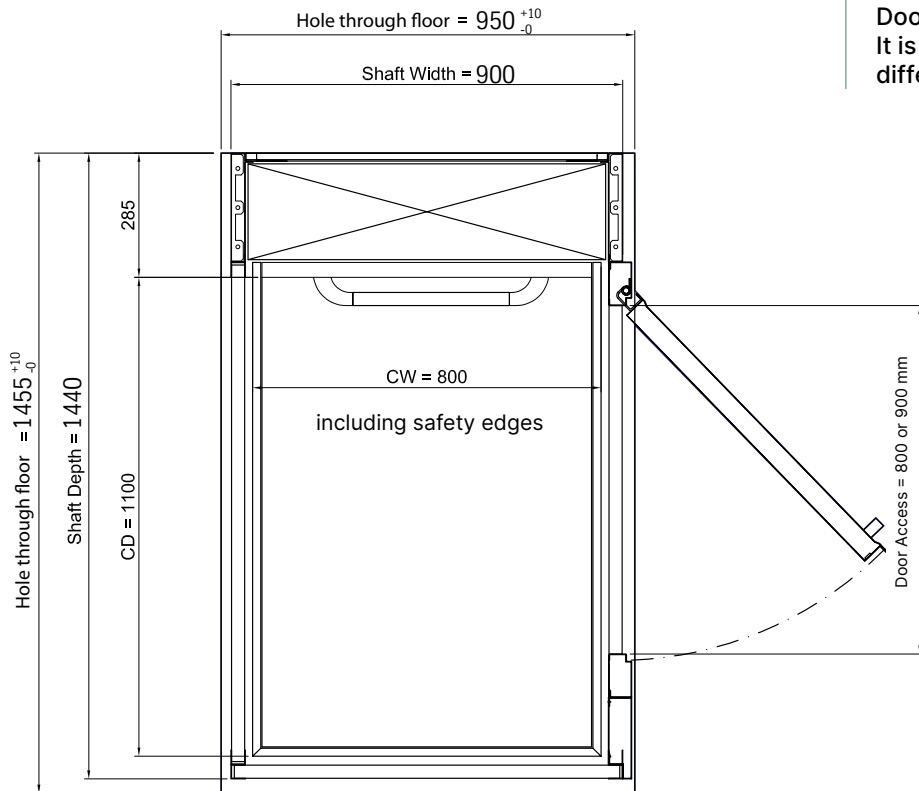
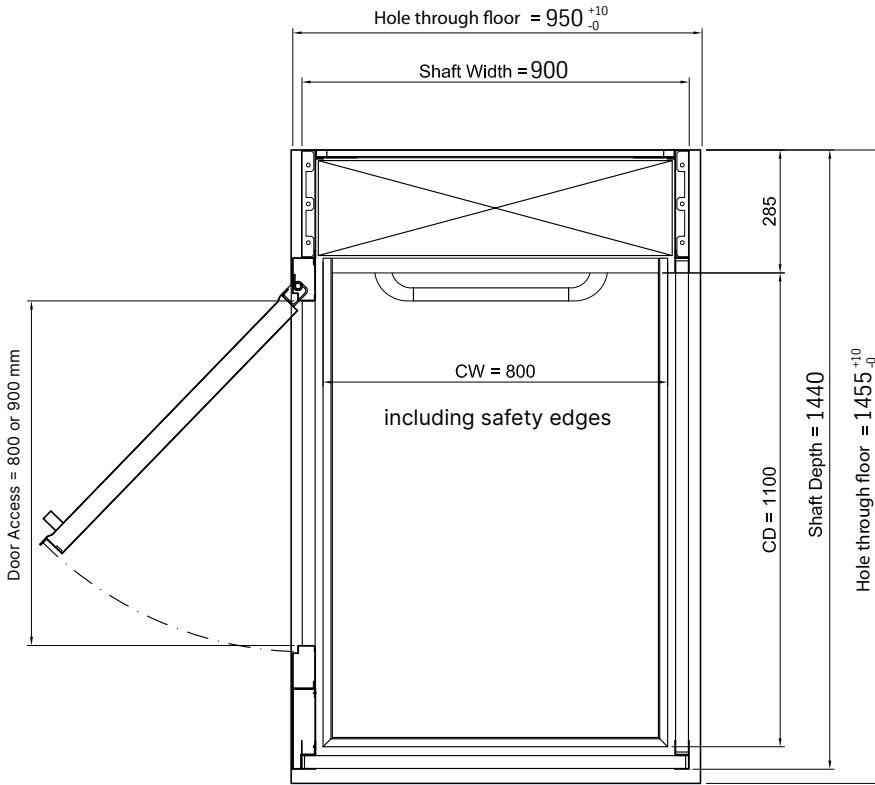

This plans can be ordered with Doors 800 mm or 900 mm. It is not possible to have doors of different size on the same unit.



## Altura Gold - Full Panel - 800×1100 - Adjacent

Max one door at the same floor

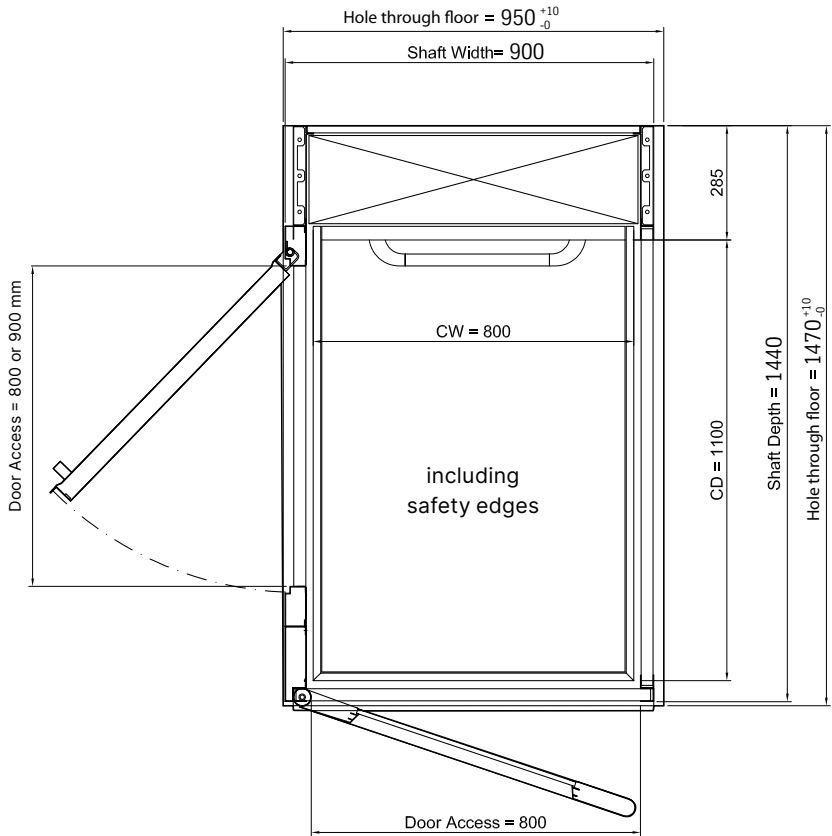

This plans can be ordered with Doors 800 mm or 900 mm on side A/C  
At these sides, it is not possible to have doors of different size

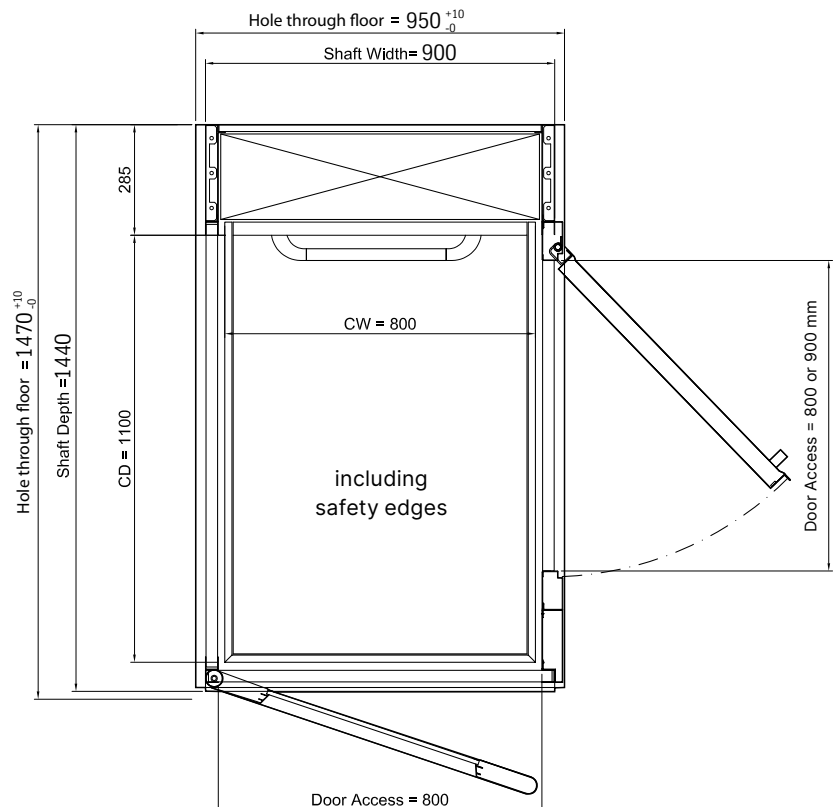

Adjacent accesses are possible with doors at different floors with minimum distance of 2300mm between floors

# Additional layout

## Altura Gold - Full Panel - 800×1100

3 access sides - Max one door at the same floor

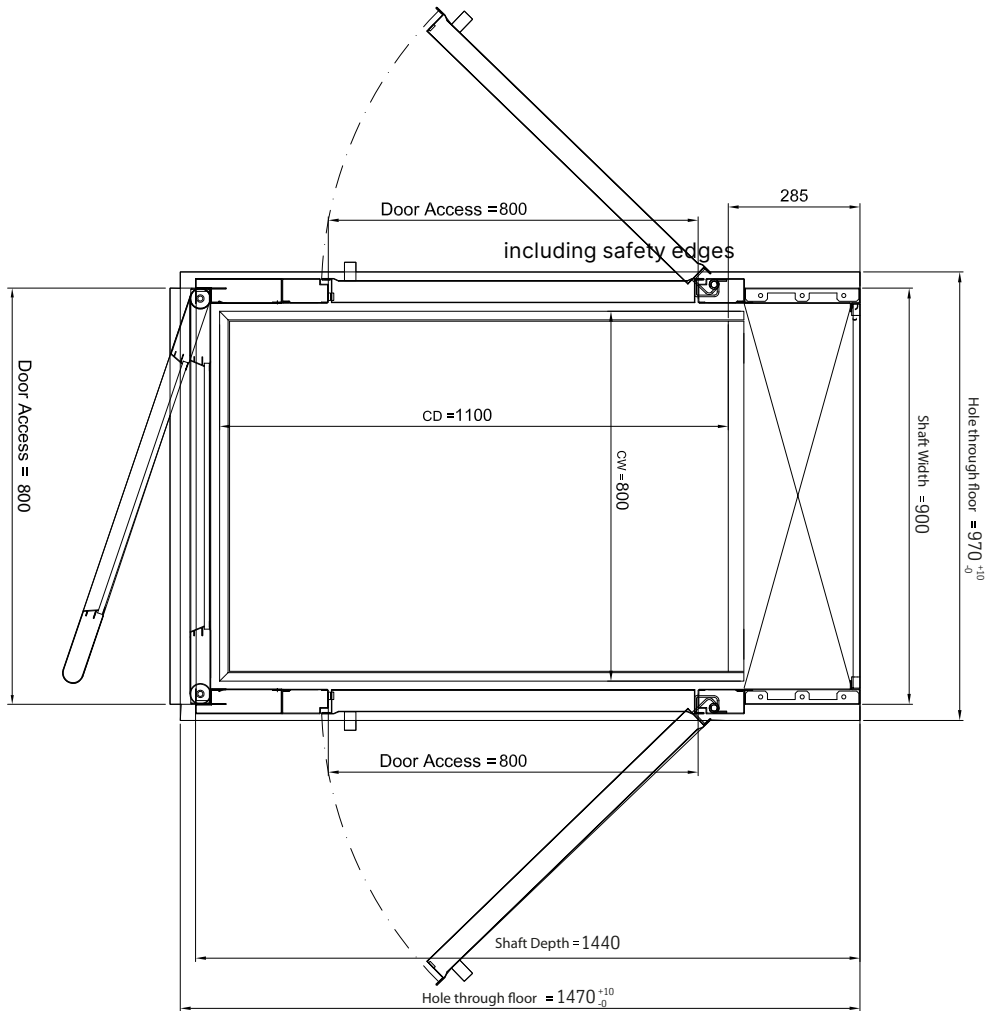

# Annexes

## **DWG-H100**

Includes the drawings of all the plan sizes available for Altura Gold.

## **RAL-Colours-Groups**

Includes the RAL colours grouped in classes.

All images and colours are for illustrative purpose only.

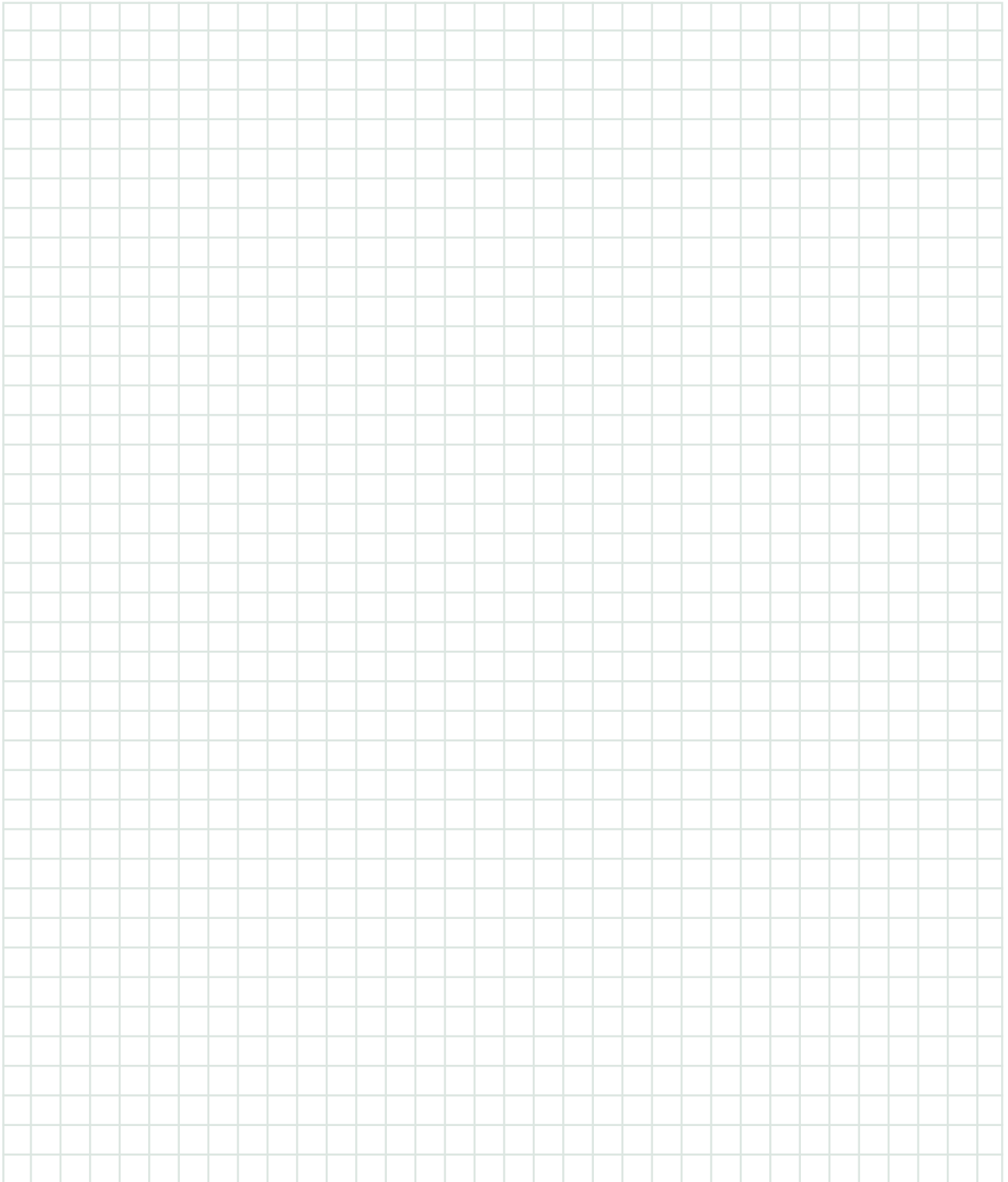

Model Code  
SN04

Product Codes  
SN04-LS-FPC  
SN04-LS-FPR

Commercial Names  
Altura Gold

Document name  
CAT-GOLD-09a

Date  
December 2023